

**Features**

- $V_{DS}=40V, I_D=90A$   
 $R_{ds(on)}(typ)=5.8m\Omega @ V_{GS}=4.5V$   
 $R_{ds(on)}(typ)=4.6m\Omega @ V_{GS}=10V$
- 100% Avalanche Tested
- 100% Rg Tested
- Lead-Free (RoHS Compliant)

**Applications**

- DC Motor Control
- DC-DC Converters
- BMS
- SMPS
- Automotive Environment

**Internal Circuit and Pin Description**

Package	TO-220	TO-263	TO-220N	TO-220P
Package Code	R	S	RN	RP

**Package Marking**

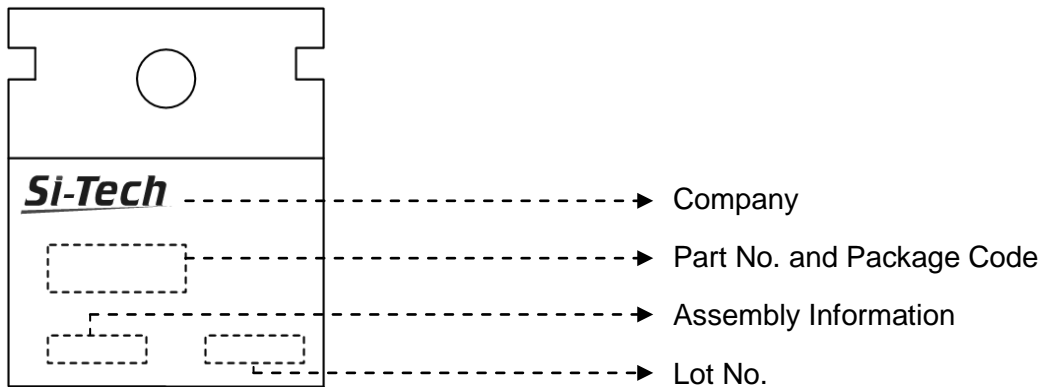

**Absolute Maximum Ratings** ( $T_C=25^\circ C$  unless otherwise noted)

Symbol	Parameter	Value	Units
$V_{DS}$	Drain-Source Voltage	40	V
$I_D$	Continuous Drain Current ( $T_C=25^\circ C$ )	90	A
	Continuous Drain Current ( $T_C=100^\circ C$ )	57	A
$I_{DM}$	Pulsed Drain Current (Note 1)	360	A
$V_{GS}$	Gate-Source Voltage	$\pm 20$	V
$E_{AS}$	Single Pulsed Avalanche Energy (Note 2)	182	mJ
$P_D$	Maximum Power Dissipation ( $T_C=25^\circ C$ )	93	W
	Derating Factor above $25^\circ C$	0.74	W/ $^\circ C$
$T_J$	Operating Junction Temperature Range	-55 to +150	$^\circ C$
$T_{STG}$	Storage Temperature Range	-55 to +150	$^\circ C$

**Thermal Characteristics**

Symbol	Parameter	Value	Units
$R_{th(j-c)}$	Thermal Resistance, Junction to case	1.34	°C/W

**Electrical Characteristics** ( $T_c=25^\circ\text{C}$  unless otherwise noted)

Symbol	Parameter	Test Conditions	Min.	Typ.	Max.	Units
$BV_{DSS}$	Drain-Source Breakdown Voltage	$V_{GS}=0V, I_D=250\mu A$	40	-	-	V
$I_{DSS}$	Drain-Source Leakage Current	$V_{DS}=38V, V_{GS}=0V$	-	-	1	$\mu A$
$I_{GSS}$	Gate Leakage Current, Forward	$V_{GS}=20V, V_{DS}=0V$	-	-	100	nA
	Gate Leakage Current, Reverse	$V_{GS}=-20V, V_{DS}=0V$	-	-	-100	nA
$V_{GS(th)}$	Gate Threshold Voltage	$V_{GS}=V_{DS}, I_D=250\mu A$	1.5	2	2.5	V
$R_{DS(on)}$	Drain-Source On-State Resistance	$V_{GS}=4.5V, I_D=40A$	4.6	5.8	7	$m\Omega$
		$V_{GS}=10V, I_D=40A$	3.6	4.6	5.5	$m\Omega$
$Q_g$	Total Gate Charge	$V_{DD}=30V$	-	43	-	nC
$Q_{gs}$	Gate-Source Charge	$V_{GS}=4.5V$	-	11	-	nC
$Q_{gd}$	Gate-Drain Charge	$I_D=40A$ (Note 3)	-	18	-	nC
$t_{d(on)}$	Turn-on Delay Time	$V_{DD}=37.5V, V_{GS}=10V$	-	22	-	ns
$t_r$	Turn-on Rise Time	$I_D=45A, R_G=4.7\Omega$	-	30	-	ns
$t_{d(off)}$	Turn-off Delay Time	$T_c=25^\circ\text{C}$	-	72	-	ns
$t_f$	Turn-off Fall Time	(Note 3)	-	41	-	ns
$R_g$	Gate Resistance	$V_{DS}=0V, V_{GS}=0V, f=1\text{MHz}$	-	1.9	-	$\Omega$
$C_{iss}$	Input Capacitance	$V_{DS}=25V$	-	2122	-	pF
$C_{oss}$	Output Capacitance	$V_{GS}=0V$	-	275	-	pF
$C_{rss}$	Reverse Transfer Capacitance	$f = 1\text{MHz}$	-	164	-	pF

**Source-Drain Diode Characteristics** ( $T_c=25^\circ\text{C}$  unless otherwise noted)

Symbol	Parameter	Test Conditions	Min.	Typ.	Max.	Units
$I_S$	Continuous Source Diode Forward Current		-	-	90	A
$I_{SM}$	Pulsed Source Diode Forward Current (Note 1)		-	-	360	A
$V_{SD}$	Forward On Voltage	$V_{GS}=0V, I_S=45A$	-	0.9	1	V
$t_{rr}$	Reverse Recovery Time	$V_{GS}=0V, I_S=45A$	-	40	-	ns
$Q_{rr}$	Reverse Recovery Charge	$dI_F/dt = 100A/\mu s$	-	71	-	nC

Notes:

1. Repetitive Rating: Pulse width limited by maximum junction temperature
2.  $L=0.5\text{mH}, V_{DD}=36V, R_G=25\Omega$ , Starting  $T_J=25^\circ\text{C}$
3. Pulse Width  $\leq 300\ \mu s$ ; Duty Cycle  $\leq 2\%$

Typical Characteristics

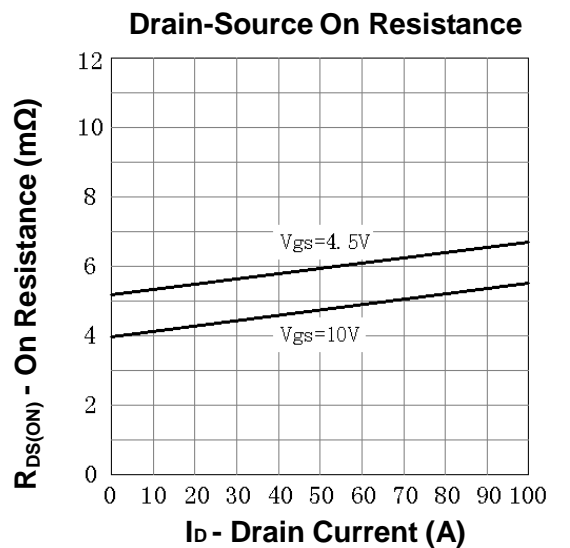
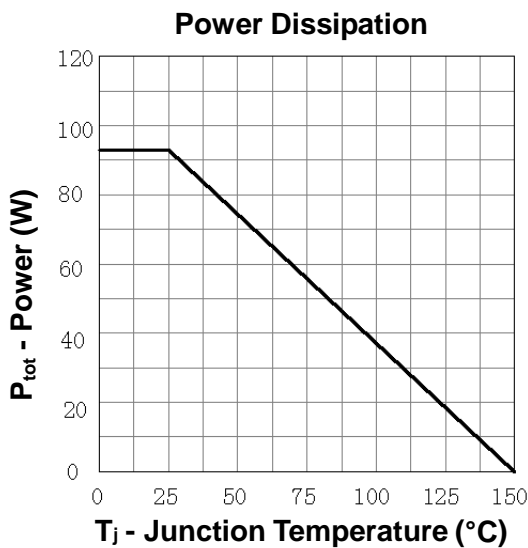
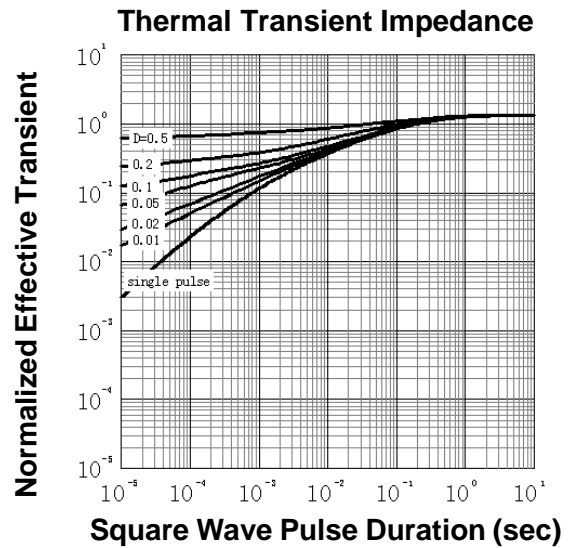
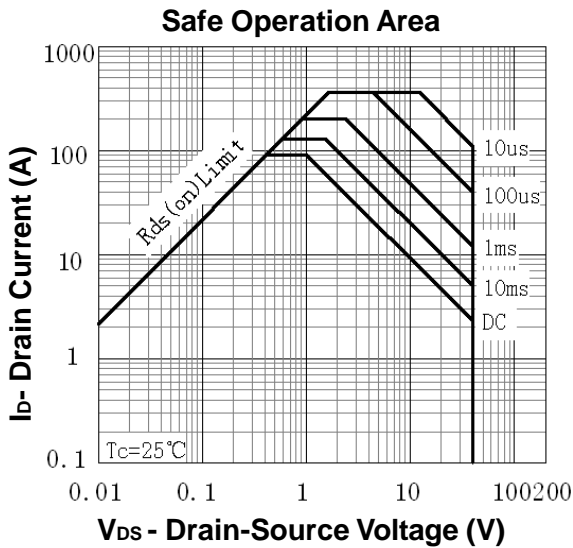
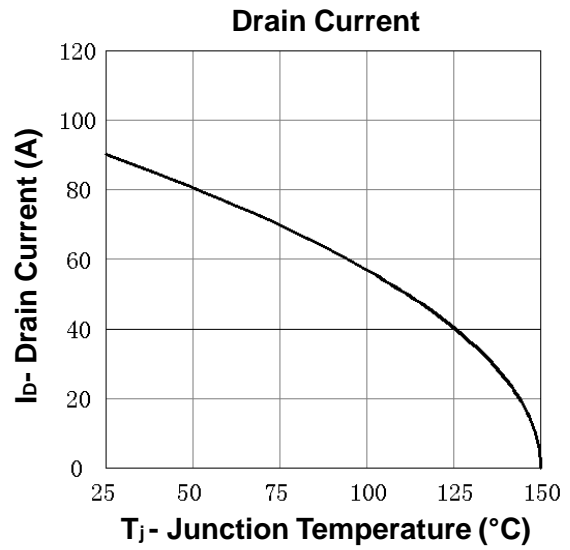
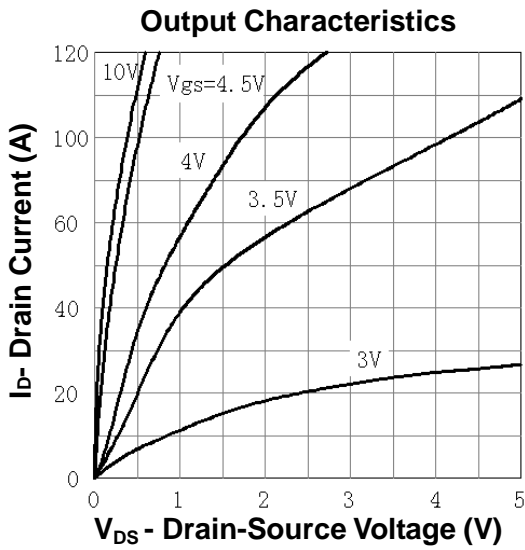

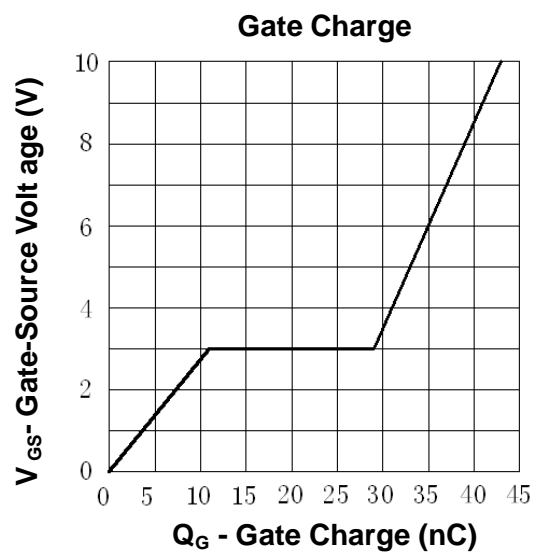
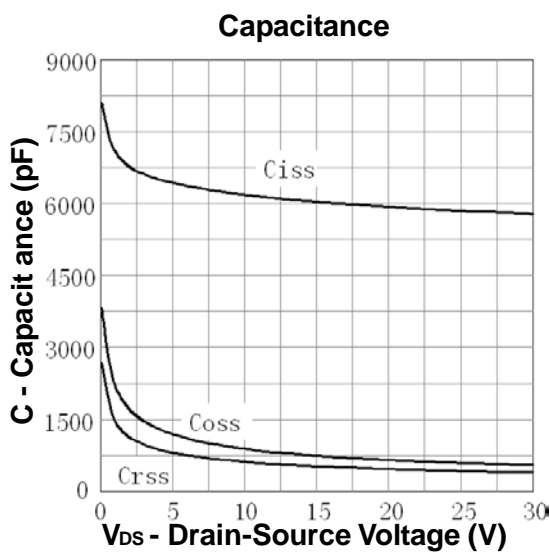
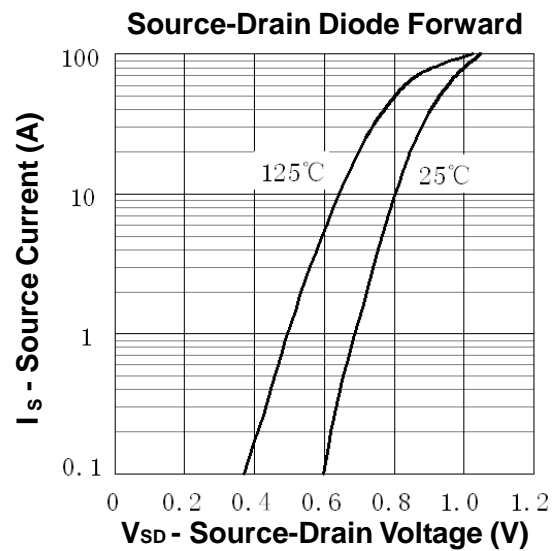
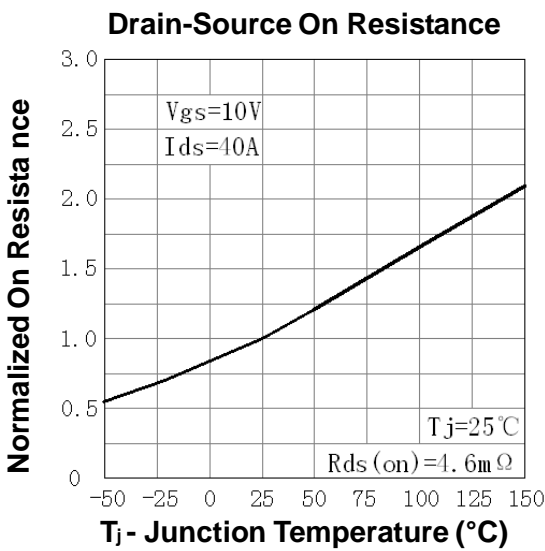
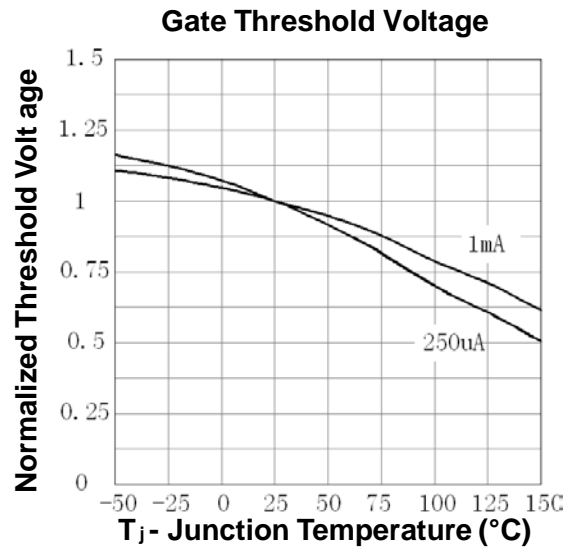
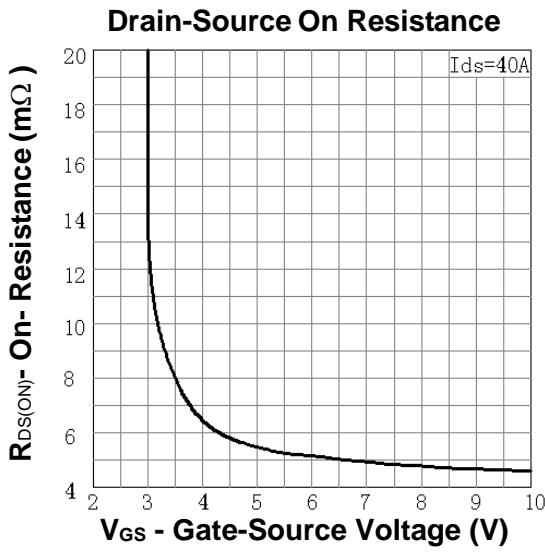

**Gate Charge Test Circuit and Waveforms**

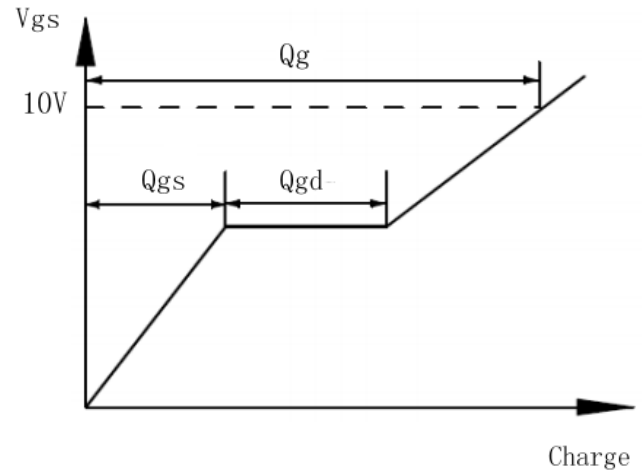
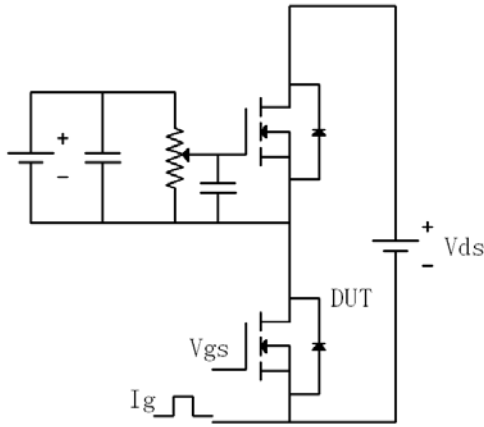

**Switching Time Test Circuit & Waveforms**

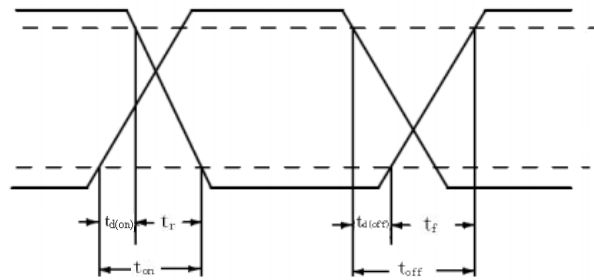
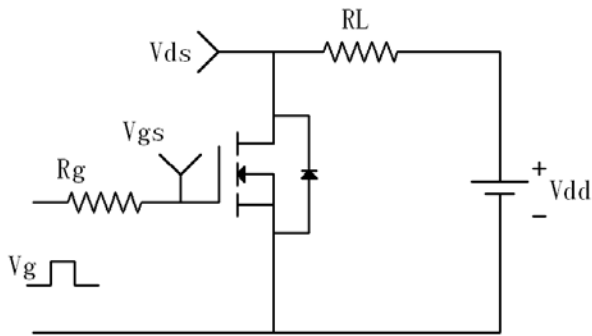

**Avalanche Test Circuit & Waveforms**

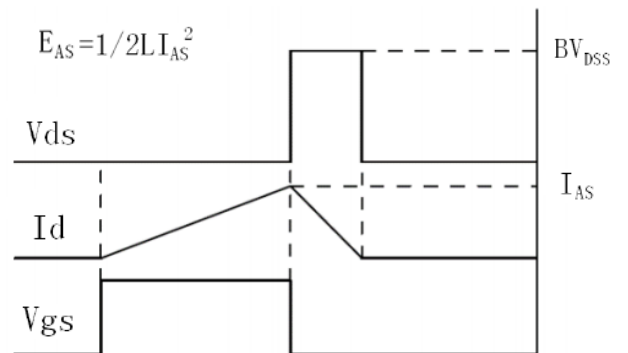
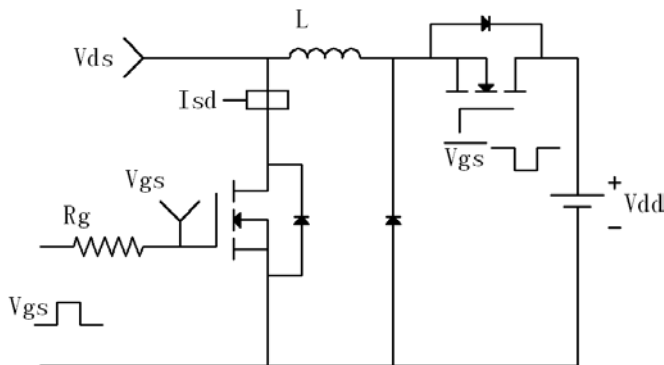

Package Outline

TO220

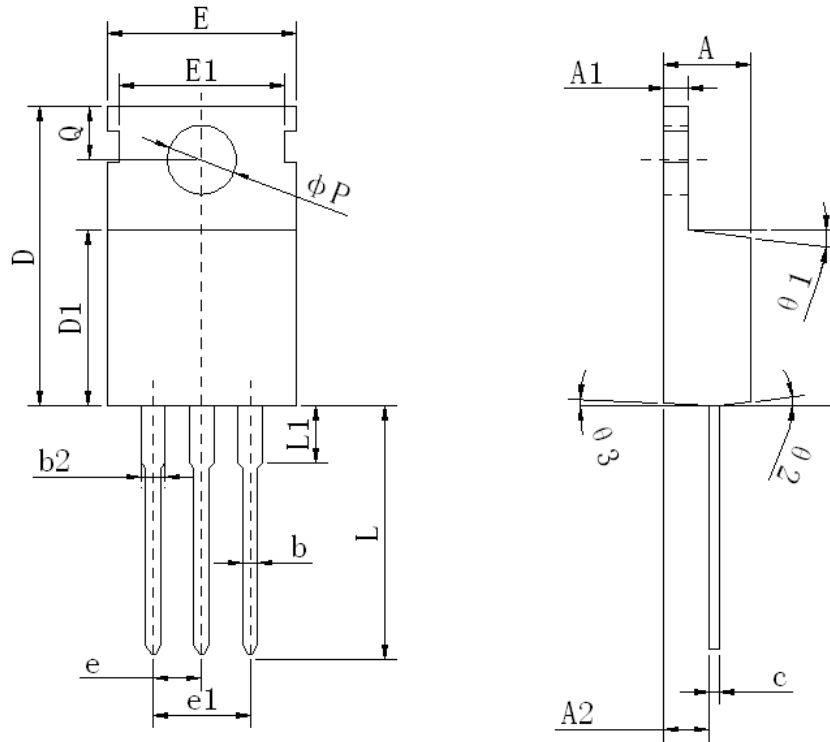

UNIT:mm

SYMBOL	MIN	NOM	MAX
A	4.47	4.57	4.67
A1	1.27	1.30	1.33
A2	2.35	2.40	2.45
b	0.76	0.80	0.89
b2	1.23	1.27	1.38
c	0.47	0.50	0.53
D	15.60	15.70	15.80
D1	9.10	9.20	9.30
E	9.70	9.90	10.10
E1	-	8.70	-
e	2.54 BSC		
e1	5.08 BSC		
L	12.83	13.00	13.17
L1	3.00	3.10	3.20
P	3.57	3.60	3.63
Q	2.75	2.80	2.85
theta 1	5°	7°	9°
theta 2	1°	3°	5°
theta 3	1°	3°	5°

TO263

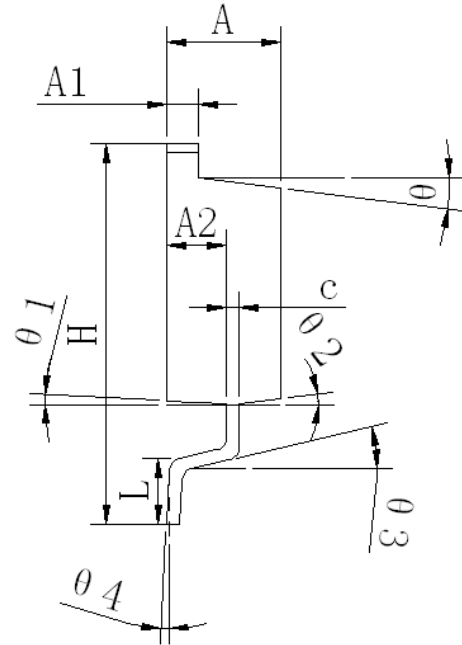
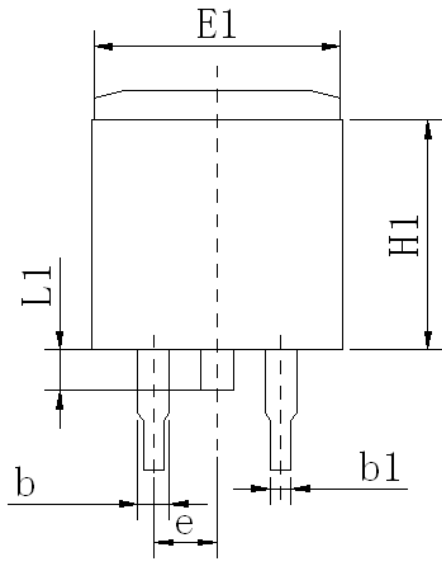

UNIT:mm

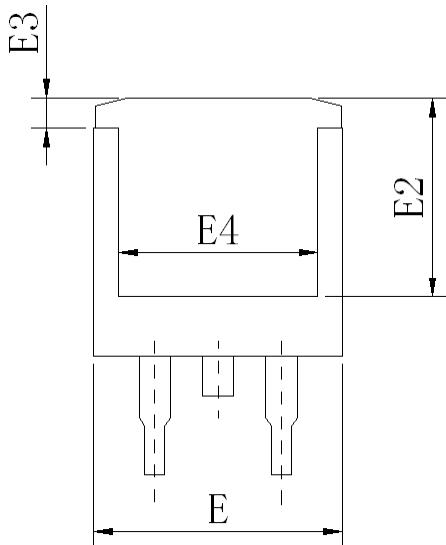

SYMBOL	MIN	NOM	MAX
A	4.47	4.57	4.67
A1	1.25	1.30	1.35
A2	2.34	2.40	2.46
b	1.22	1.27	1.32
b1	0.75	0.80	0.85
c	0.45	0.50	0.55
E	9.90	10.00	10.10
E1	9.78	9.88	9.98
E2	7.95	8.00	8.05
E3	1.10	1.20	1.30
E4	7.95	8.00	8.05
e	2.54 BSC		
H	15.00	15.20	15.40
H1	10.30	10.40	10.50
L	2.20	2.40	2.60
L1	1.50	1.60	1.70
$\theta$	5°	7°	9°
$\theta1$	1°	3°	5°
$\theta2$	5°	7°	9°
$\theta3$	11°	13°	15°
$\theta4$	0°	2°	5°